



2141 ICON Way, Vacaville, CA 95688 - Tel: 707.564.4000 – www.iconaircraft.com

SAFETY DIRECTIVE/ALERT

SD-111521-C

DATE ISSUED: 08/15/2022
DATE EFFECTIVE: 08/15/2022
SUBJECT: Slipping Autopilot Bridle Cable Clamps
AIRCRAFT AFFECTED: **MODEL:** A5
S/N: 00139-00142, 145, and 149
REQUIRED ACTION: Disable autopilot system.
TIME OF COMPLIANCE: Complete before next flight

PURPOSE: ICON aircraft has become aware that it is possible for the G3X Autopilot-equipped aircraft to experience slippage and/or rotation of the autopilot servo-to control cable bridle clamps. Loosening and misalignment of the noted hardware can lead to slack in the flight controls with the autopilot engaged, creating the possibility of flight control jams in pitch and/or roll. All affected aircraft must have the autopilot system disabled until further notice from ICON Aircraft.

INSTRUCTIONS:

Removal of existing assemblies, subassemblies, or detail parts:

It is permissible to disassemble the aircraft as required to permit accessibility, inspection, adjustment, maintenance, and repair in accordance with the latest release of the Aircraft Maintenance Manual, ICA000833.

1. Extend and/or fold the wings to gain access to the fuselage roll components.
2. In accordance with the Aircraft Maintenance Manual, remove the following components to gain access to the roll and pitch bridle cables, and retain all hardware for reinstallation:
 - a. Headliner Removal: [100253](#)
 - b. Baggage Floor Removal: [100050](#)
 - c. Left- And Right-Hand Baggage Sidewall Removal: [100054](#)
 - d. Left- and Right-hand main cockpit sidewalls and cushions (section 3.6.2.13)
 - e. Left- and Right-hand seatbacks (3.6.2.15)
 - f. Fuel tank (section 10.5.1.1).
3. Install rig pins into the roll sockets in accordance with the Aircraft Maintenance Manual, Section 9.4.4.1. This step is to secure the upper roll cable during step 7 and may be omitted if the roll sockets can be secured from moving manually (multiple operators required).
4. Loosen and remove the screws, nuts, and washers that secure the inboard bridle cable clamp to the upper roll cable. See **Figure 1**. Discard the clamp halves and the hardware.
5. Loosen and remove the hardware securing the pilot side roll socket. Ensure to make note of the location of each washer for re-installation. Remove the rig pins that were installed in step 3. Pass the roll socket, and attached cabling, inboard to gain access to the outboard bridle cable clamp.
 - a. As an alternative process to removing the roll socket, with rig pins installed, remove the turnbuckle locking clips from the upper roll cable turnbuckle and loosen the turnbuckle. Remove the screw, nut, and washers that secure the upper roll cable to the roll socket,

SAFETY DIRECTIVE/ALERT

SD-111521-C

attach a retrieval wire or string to the bearing and pass the cable and bearing inboard to gain access to the outboard bridle cable clamp.

6. Loosen and remove the screws, nuts, and washers that secure the outboard bridle cable clamp to the upper roll cable. Discard the clamp halves and the hardware.
7. Loosen and remove the screws, nuts, and washers that secure the bridle cable clamps to the upper pitch control cable. See **Figure 2**. Discard the clamp halves and the hardware.

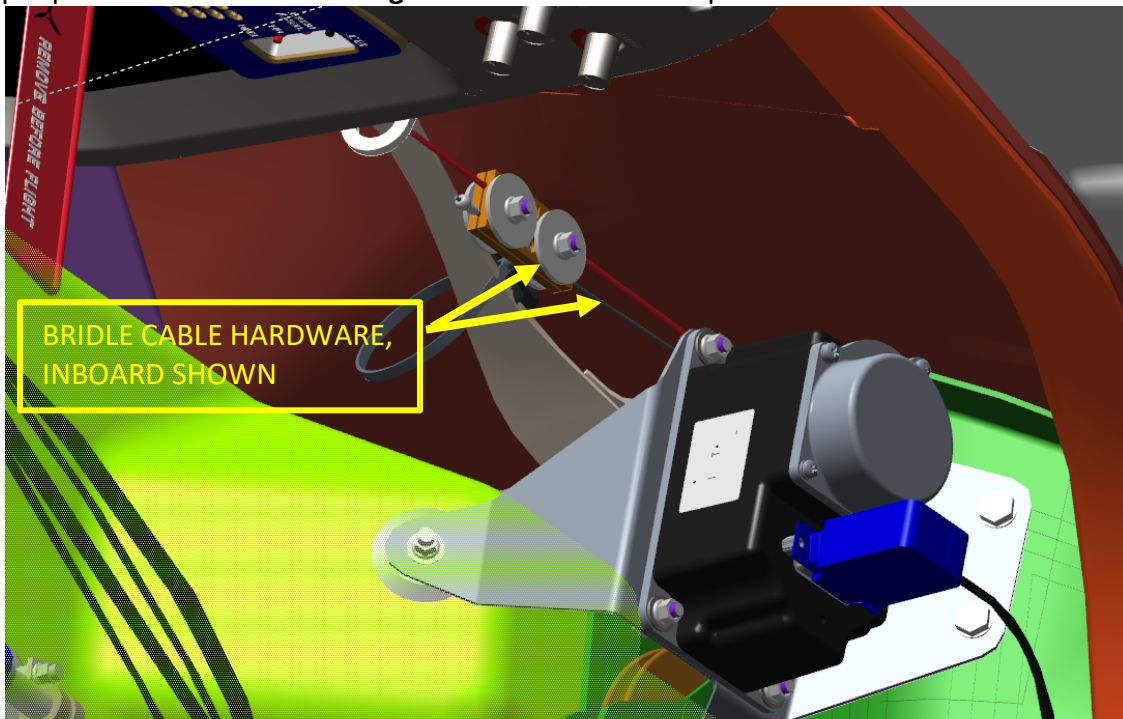

Figure 1: Remove inboard bridle cable clamp.

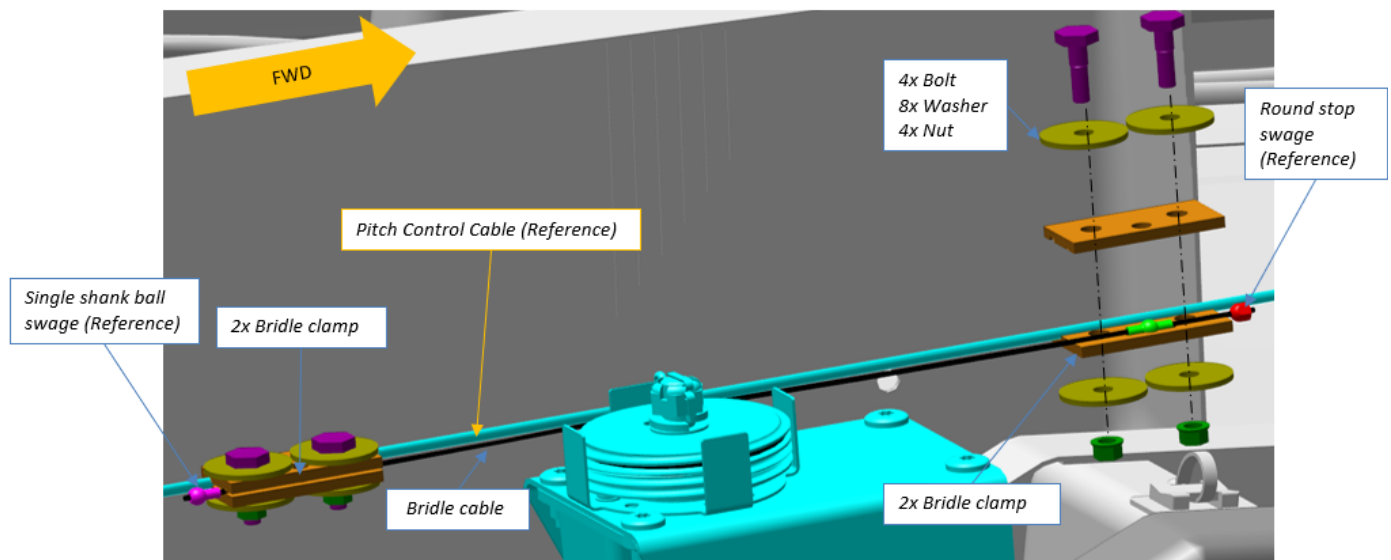

Figure 2: Remove bridle cable clamps.

SAFETY DIRECTIVE/ALERT**SD-111521-C**

8. Disconnect the control harness connector, D9140P, from the roll servo
9. Disconnect the control harness connector, D9148P, from the pitch servo.
10. Remove the 2 bolts that secure the roll servo bracket to the left-hand center wing root rib. Retain hardware for reinstallation. See **Figure 3**.
11. Remove the nut and washer that secure the roll servo bracket to the stud bonded to the center wing spar. Retain hardware for reinstallation. See **Figure 3**.
12. Loosen the nut and bolt securing the upper roll cable pulley just enough so that the roll servo and the mount bracket can be removed as the bracket is slotted in this location. See **Figure 3**. Retain the roll servo and mount bracket for later reinstallation.

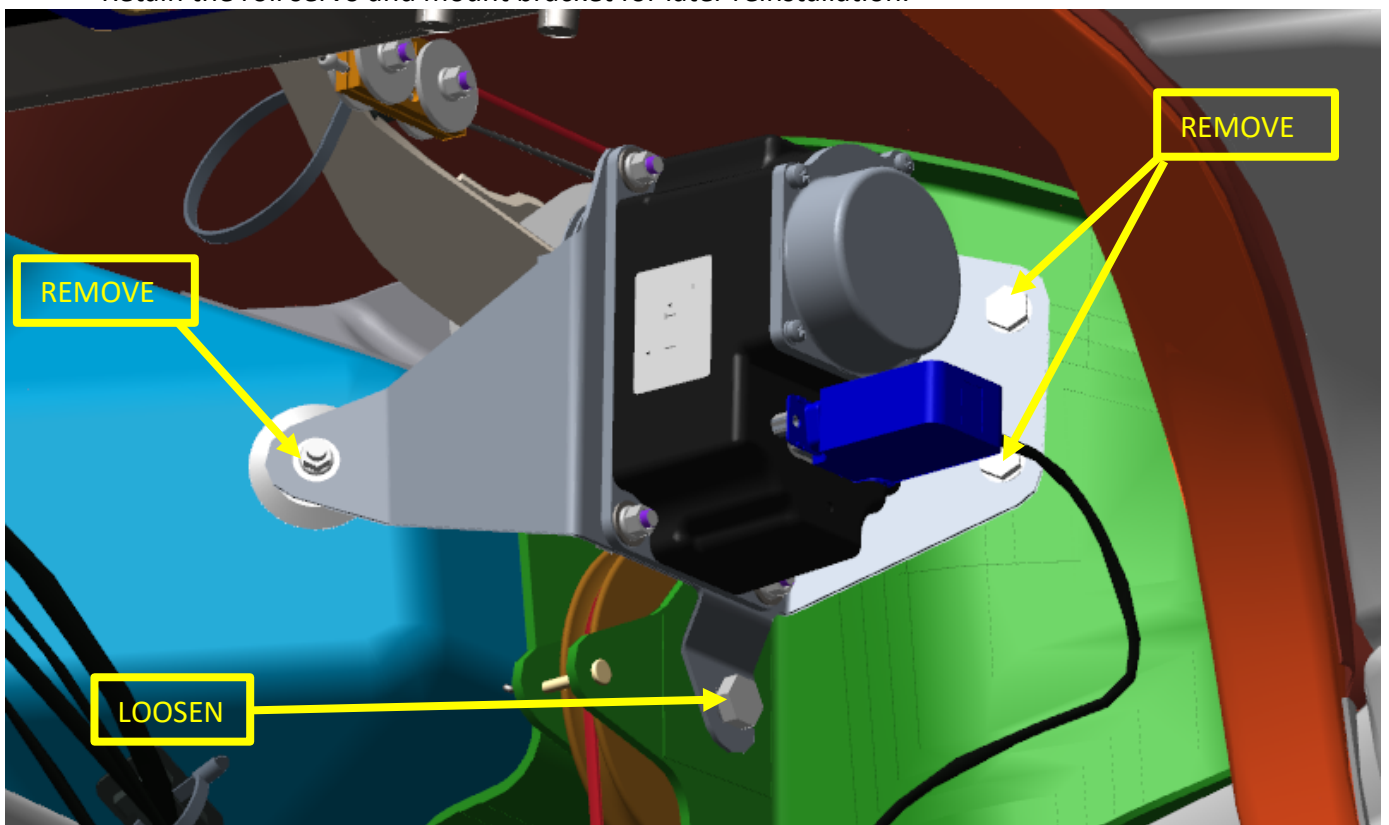

Figure 3: Loosen and Remove hardware

13. Remove the four screws and washers that secure the pitch servo and its mount bracket to the keel of the aircraft and remove the pitch servo and bracket. Retain the servo, bracket, and mounting hardware for later reinstallation. See **Figure 4**.
14. Remove the 5 Amp "AUTOPILOT" fuse located at the front of the fuse panel on the co-pilot side of the overhead console. Retain for later reinstallation.

SAFETY DIRECTIVE/ALERT

SD-111521-C

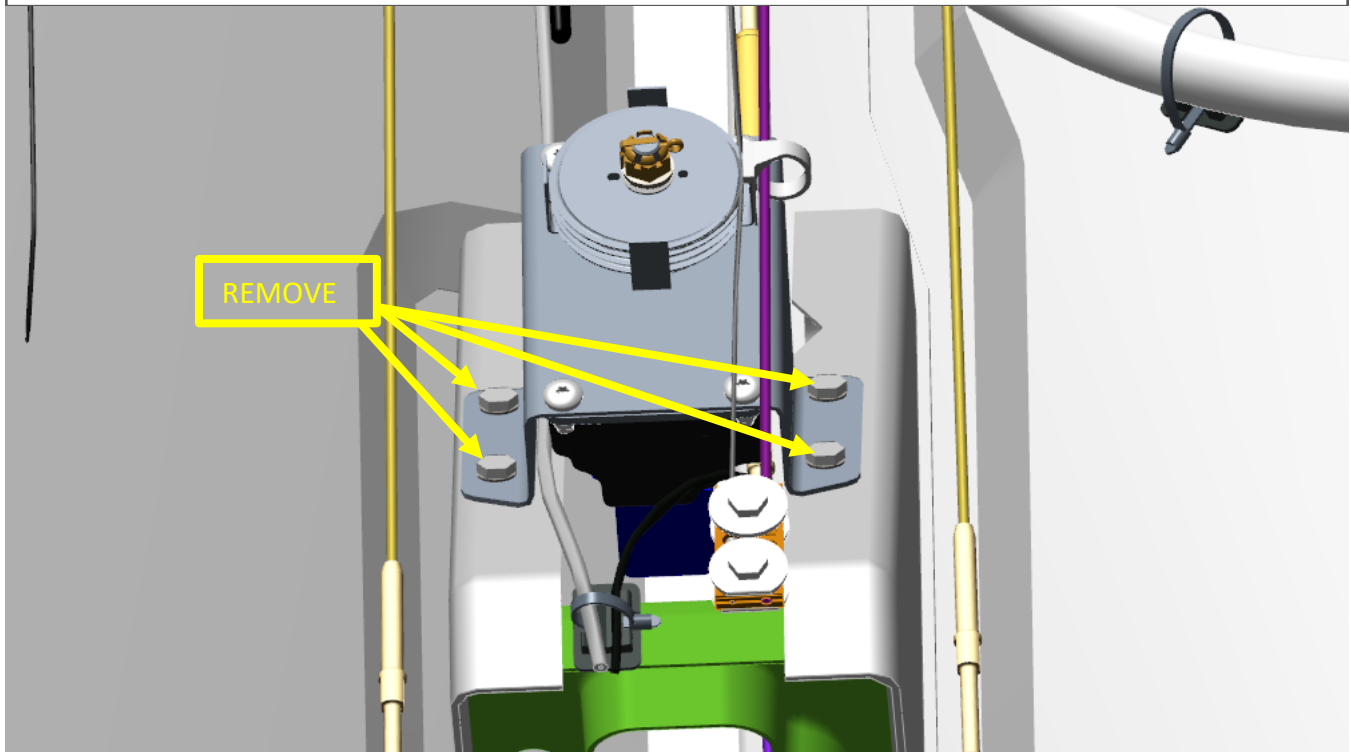

Figure 4: Remove hardware

CORRECTIVE ACTION:

Consumable and bulk materials list:

P/N	Description	Qty
ICA014693	REMOVAL ADAPTER, GSA 28, GARMIN	2
TY24MX	CABLE-TIE, NYLON 6-6, 30LB, 5.50, TY-RAP	2
ICA012079	Inspector's lacquer	As Required
TY23MX	CABLE-TIE, NYLON 6-6, 18LB, TY-RAP	4

Installation:

1. Obtain 2 each Garmin GSA28 Removal Adapters (ICA014693) and remove both locknuts and female screwlocks from each adapter. Discard the locknuts and screwlocks.
2. Remove both screws from the pitch servo connector, D9148P.
3. Install ICA014693, Removal Adapter (find number 22), onto servo connector, D9148P and secure in place with 2 each TY23MX cable ties. See **Figure 6**. Stow branch to wire harness using 1 each TY24MX in the approximate area indicated by flag note 35 in **Figure 5**.
4. Remove both screws from the roll servo connector, D9140P.

SAFETY DIRECTIVE/ALERT

SD-111521-C

5. Install ICA014693, Removal Adapter (find number 22), onto servo connector, D9140P and secure in place with 2 each TY23MX cable ties. See **Figure 6**. Stow branch to wire harness using 1 each TY24MX in the approximate area indicated by flag note 34 in **Figure 5**.

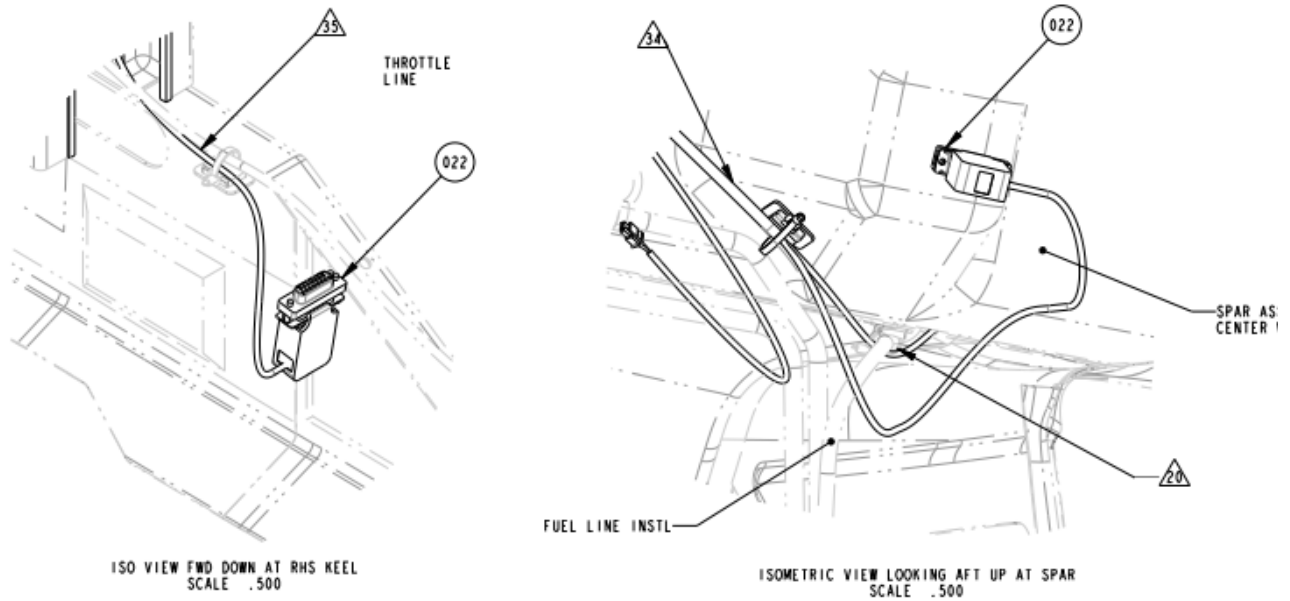

Figure 5: Cap and stow servo connectors

SAFETY DIRECTIVE/ALERT

SD-111521-C

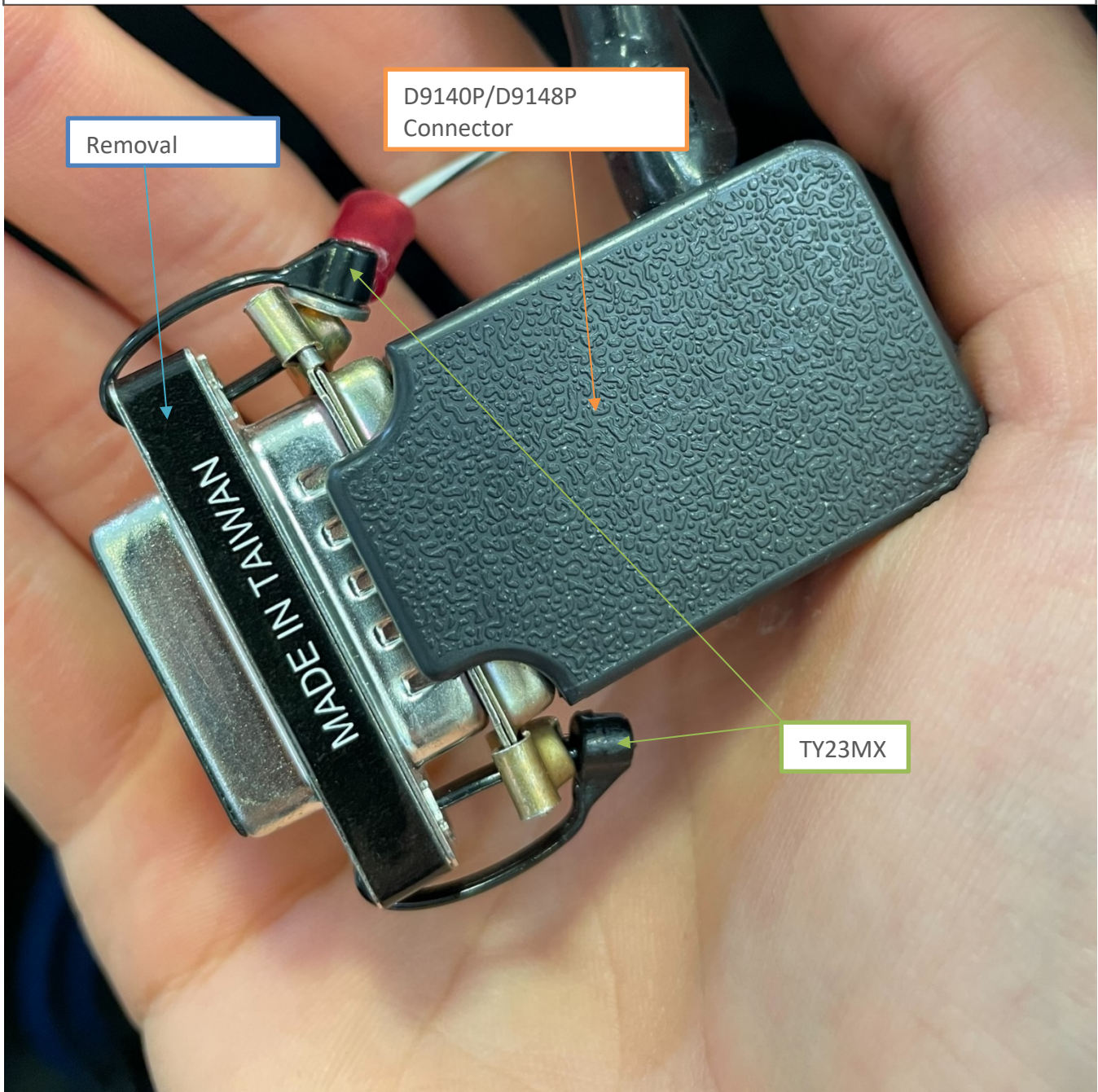

Figure 6: Cap connectors with F4 tape

15. Tighten the nut and bolt that were loosened in step 12 to 38.4-48.4 in-lbs.
16. If removed, reposition the pilot side roll socket in place at the pilot-side end of the center wing and reinstall the mounting hardware removed in step 5. Torque and apply inspector's lacquer as shown in Error! Reference source not found.7. If the removal step 5 alternative method was used, reposition the upper roll cable bearing in the roll socket and reinstall the screw, washers, and

SAFETY DIRECTIVE/ALERT**SD-111521-C**

nut. Torque to 16.4-19.4 in-lbs.

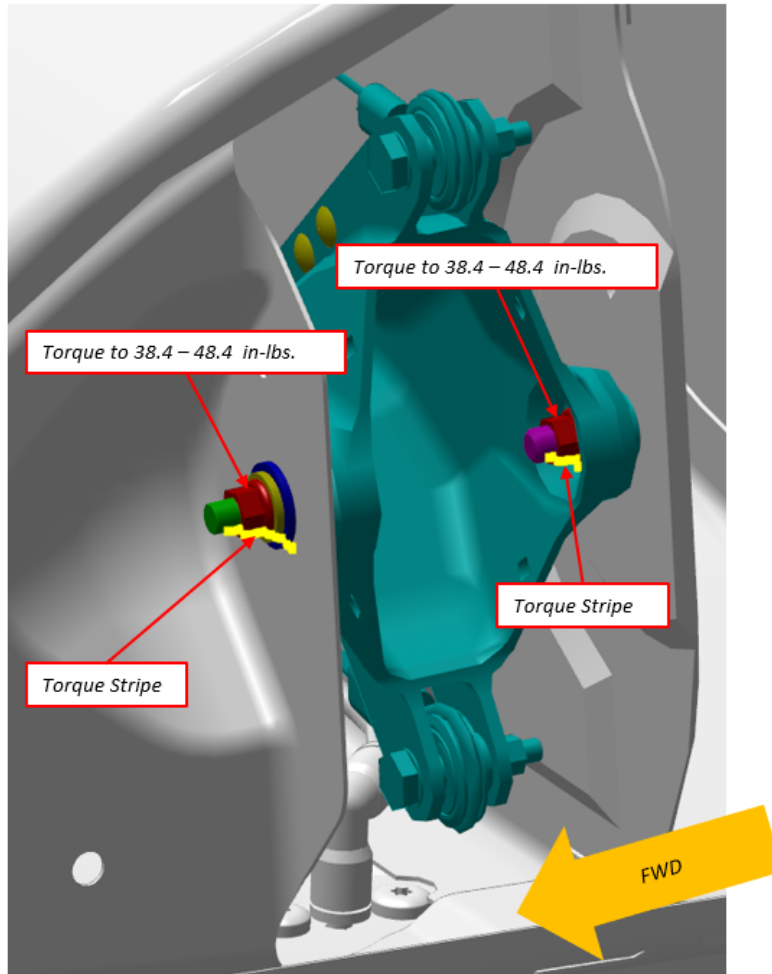

Figure 7: Roll socket reassembly.

17. Verify roll system rigging in accordance with the aircraft maintenance manual.
18. Reassemble, in accordance with the aircraft maintenance manual, the following components that were removed to gain access to the roll and pitch bridle cables:
 - a. Headliner (section 3.6.2.2)
 - b. Left- and right-hand baggage floor panels (section 3.6.2.8)
 - c. Baggage floor (section 3.6.2.6)
 - d. Left- and right-hand main cockpit sidewalls and cushions (section 3.6.2.14)
 - e. Left- and right-hand seatbacks (3.6.2.16)
 - f. Fuel tank (section 10.5.1.2).



2141 ICON Way, Vacaville, CA 95688 - Tel: 707.564.4000 – www.iconaircraft.com

SAFETY DIRECTIVE/ALERT

SD-111521-C

Hardware noted to remove and retain until further notice:

P/N	Description	Qty
Roll System		
ME001101	Autopilot Roll Servo/Bracket Subassy	1
MS21043-3	Nut	1
AN3C4A	Bolt	2
NAS1149C0332R	Washer	3
Pitch System		
ME001100	Autopilot Pitch Servo/Bracket Subassy	1
AN34CA	Bolt	4
NAS1149C0332R	Washer	3
Other		
ICA011204	5 Amp Fuse	1

19. Complete new weight and balance measurement in accordance with the Aircraft Maintenance Manual, section 2.13.
20. Enter configuration mode on the G3X (procedure below) and make the following changes:
 - a. Flip the Master Switch ON
 - b. Immediately press and hold the menu key on the G3X display
 - c. Hold this key down until the display acknowledges that it is entering configuration mode
 - d. Go into the LRU submenu

SAFETY DIRECTIVE/ALERT

SD-111521-C

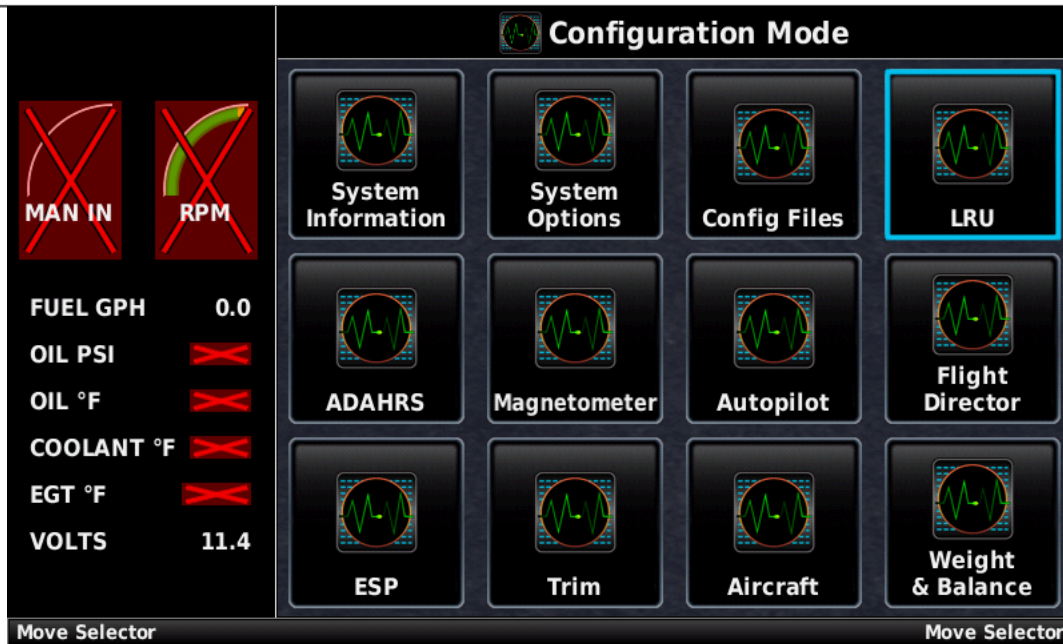

- e. Set “Garmin Autopilot Servos” to “None”

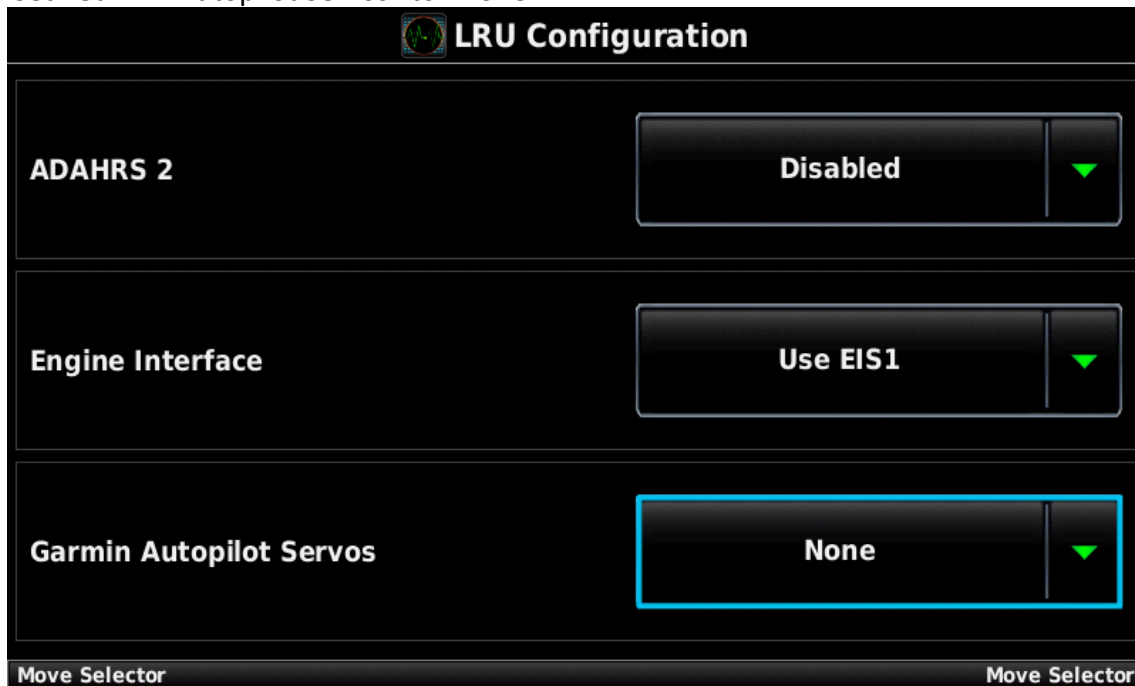

- f. Go into Weight & Balance submenu
 g. Update “Empty CG Arm” value to match new value from weight and balance measurement
 h. Update “Empty Weight” value to match new value from weight and balance measurement

SAFETY DIRECTIVE/ALERT

SD-111521-C

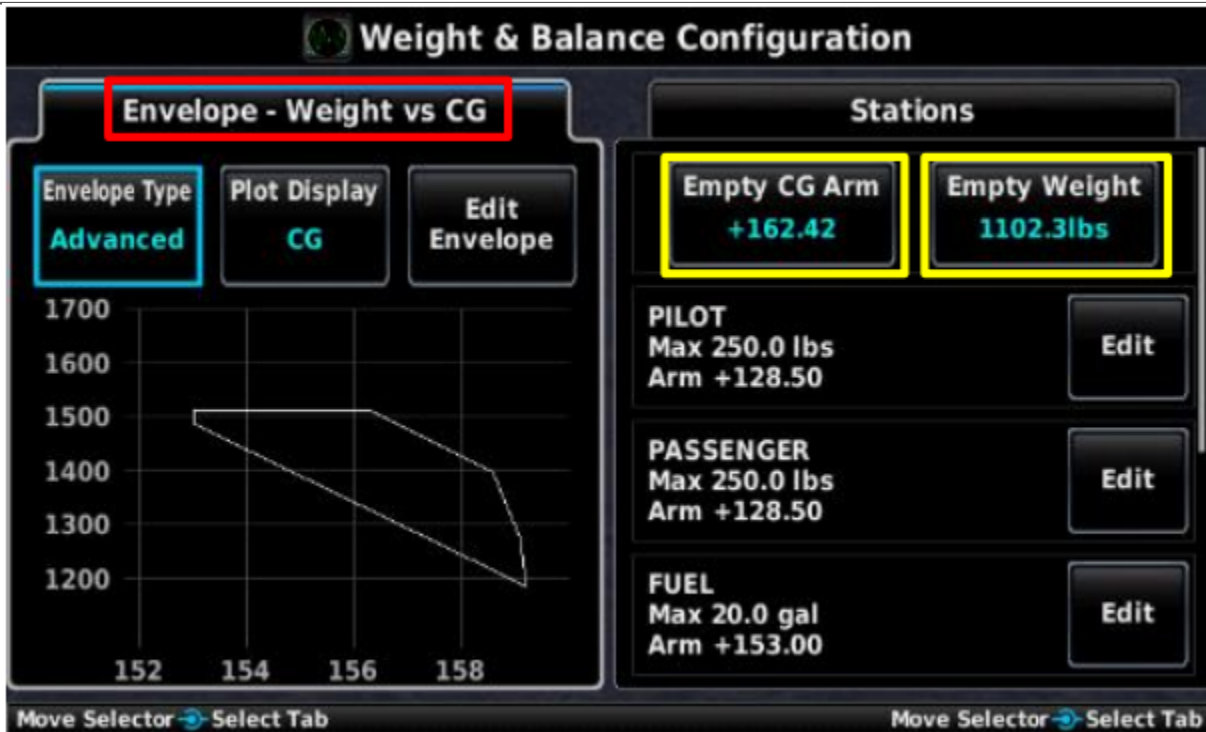

- i. Select “Save & Reboot” option on the bottom of the configuration menu

21. Apply a label displaying “INOP” to the center stack as shown in Figure 8.



2141 ICON Way, Vacaville, CA 95688 - Tel: 707.564.4000 – www.iconaircraft.com

SAFETY DIRECTIVE/ALERT

SD-111521-C



Figure 8: "INOP" label installation

Make the following logbook entry:

"The corrective action of Safety Directive/Alert SD-111521-B has been complied with and reported to ICON Aircraft Service."

Notify ICON Aircraft of Safety Directive/Alert compliance. (support@iconaircraft.com)

Warranty Information:

ICON Certified Service Providers: Please submit an invoice for warranty reimbursement for labor upon completion of this Safety Directive/Alert. Please reference Safety Directive number SD-111521-B.



2141 ICON Way, Vacaville, CA 95688 - Tel: 707.564.4000 – www.iconaircraft.com

SAFETY DIRECTIVE/ALERT

SD-111521-C

10 hours for disabling the autopilot system.

If you have questions, comments, or concerns about this Safety Directive/Alert and/or if you are no longer owner/operator of this aircraft, please forward this information to the present owner/operator and notify ICON Aircraft at:

ICON Aircraft
2141 ICON Way
Vacaville, CA 95688
(855) FLY-ICON or (707) 564-4000
support@iconaircraft.com

Please include the aircraft registration number, serial number, your name, and if known the contact information of the new owner/operator.