



2141 ICON Way, Vacaville, CA 95688 - Tel: 707.564.4000 – www.iconaircraft.com

SERVICE BULLETIN

SB-112221 REV A

DATE ISSUED: 12/13/2021
DATE EFFECTIVE: 12/13/2021
SUBJECT: Fuel Pump and Connector Contact Replacement
AIRCRAFT AFFECTED: **MODEL:** A5
S/N: 00089-00092, 00094, 00096-00113, 00115-00121, 00123-00125, 00127-00131, 00133, 00135, 00139, 00142
REQUIRED ACTION: Fuel pump assembly and connector contact replacement. Additional preflight and runup checks are required until replacement.
TIME OF COMPLIANCE: Replace at next service interval not to exceed 20 hours of flight time (whichever comes first).

PURPOSE: Aircraft in the affected range may suffer poor fuel pump performance due to lack of proper contact in the electrical connectors and/or premature wear resulting in a MAIN and/or AUX fuel pump failure. Failure of a fuel pump may lead to an in-flight engine shutdown requiring an in-flight restart and possible forced emergency landing if the restart is unsuccessful. Signs of premature fuel pump wear or lack of proper contact in the electrical connectors can be detected audibly on the ground before engine start after the Master Switch is turned ON. With the Master Switch ON, the pitch and volume of the fuel pumps should be constant without fluctuations. Any fluctuation in the pitch or volume of the fuel pumps is an indication of premature fuel pump wear or an electric connector problem. Additionally, illumination of the FUEL PRESS annunciator panel caution light, even if only momentarily, during the pre-flight engine run-up procedure is an indication of mentioned findings. If any of these indicators are present, stop all aircraft operations and contact an authorized service provider for fuel pump replacement before next flight.

INSTRUCTIONS:

CORRECTIVE ACTION: ADDITIONAL PREFLIGHT CHECKS UNTIL FUEL PUMP IS REPLACED

Note: The following procedures must be performed in addition to standard procedures indicated in the POH until the Main and Aux Fuel Pumps are replaced.

1. Turn the Master Switch to ON, turn the key switch to Lane A, pause for 10 seconds and listen to the sound of the fuel pump while monitoring the FUEL PRESS annunciator panel caution light. The fuel pump should turn on and quickly reach a steady running condition with no fluctuations in pitch or volume.
2. Switch to Lane B and perform the same procedure listed in step 1.
3. Switch to "Both" and perform the same procedure listed in step 1.
4. If the FUEL PRESS caution light was not illuminated during this extended procedure and there were no audible differences between Lane A, Lane B, and Both, you may proceed to engine start.
5. During run-up lane check, if the FUEL PRESS caution light illuminates (even if only momentarily), taxi back and shut down the engine. The fuel pumps must be replaced before the next flight.



2141 ICON Way, Vacaville, CA 95688 - Tel: 707.564.4000 – www.iconaircraft.com

SERVICE BULLETIN

SB-112221 REV A

CORRECTIVE ACTION: FUEL PUMP REMOVAL AND REPLACEMENT INSTRUCTIONS

Level of Certification Required (any level checked can perform task)

- Pilot/Owner
- LSA Repairman—Inspection
- LSA Repairman—Maintenance
- A&P
- Certified Repair Station
- Manufacturer
- Named Individual

Certificate Holder's Information

Name:	
Address:	
Certificate Type & Number:	
Date:	
Signature:	

Parts, Consumables and bulk materials list if replacing fuel pumps:

P/N	Description	Qty
ME000655	Fuel Pump, Rotax 912iS, Altered	1
Torque Stripe	Torque Stripe	As Needed
Loctite 243	Threadlocker, Loctite 243	As Needed
NAS1149C0432R	WASHER, FLAT, CRES, #4X.032, PSVT	4
ICA012801	WIRE SEAL, 150 SERIES, OD 1.20-1.70MM	4
ICA011062	CONTACT, CRIMP, FEMALE, SOCKET 20-16	4
ICA013937	SEAL, CONNECTOR, ROTAX, ORANGE	2
ICA011057	CONNECTOR, CONTACT, SECONDARY LOCK, 2-POSN	2
ICA011058	CONNECTOR, RCPT, SKT, 2-POSN	2

Special tools, fixtures, or other special equipment:

- It is permissible to create and use tools and fixtures as required to properly carry out the instructions presented within this document so long as they do not cause any damage to the aircraft or create any deviation of the aircraft from its intended design.
- Hand Crimp tool – Aptiv (formerly Delphi) 12085271 or equivalent.
- Metri-Pack Terminal Removal Tool – 12094429 or equivalent.

SERVICE BULLETIN

SB-112221 REV A

Removal and Installation:

1. It is permissible to disassemble the aircraft as required to permit accessibility, inspection, adjustment, maintenance, and repair in accordance with the latest release of the Aircraft Maintenance Manual.

NOTE: Before starting repair work on the fuel system, ensure that it is no longer pressurized.

2. Purge all fuel from fuel lines.

NOTE: All operating fluids can damage the environment if not disposed of properly. Please dispose of operating fluids accordingly.

3. Remove fuel pump per the maintenance manual, section 10.7.1.1.
4. Document serial numbers for both removed fuel pumps, and both new fuel pumps in the aircraft logbook. See **Figure 1**.



Figure 1: Serial number location on fuel pump assembly

5. Locate the D9087P and D9100P connectors that connect to the fuel pump. D9100P connects at the top of the fuel pump assembly and D9087P connects at the bottom.
6. Remove the connector secondary lock from the back of each connector.
7. Make note of the wire locations within each connector and then remove the contacts from the connector using Metri-Pack Terminal Removal Tool – 12094429 or similar.
8. For steps 9 through 14, refer to **Figure 3**.
9. Cut the terminals off the fuel pump connector wires with cuts made as close to the terminals as possible. Note orientation of wire seal.

SERVICE BULLETIN

SB-112221 REV A

Note: All wiring and termination to be manufactured in accordance with process spec IPC/WHMA-A-620, Class 2. Requirements and acceptance for cable & wire harness assemblies.

10. Install 1 each blue wire seal (ICA012801) on each wire in the same orientation as the seals that were removed and slide away from the end of the wire.
11. Strip ¼” of insulation from each wire.
12. Align the blue wire seal with the end of the wire insulation.
13. Position the wire end in the terminal (ICA011062) as shown in Box 4.
14. Optional depending on the tool used: using the tool position for 16 gauge wire, crimp core wings first, then insulation wings using crimp tool 12085271 or equivalent. If the crimping tool is properly equipped, the seal crimp and the core crimp can happen simultaneously.
15. Install 1 each orange connector seal (ICA013937) onto the new connector body in the same location and orientation as the seal on the original connector. See **Figure 2**. **Note: The original connector may have either a blue seal or an orange seal in this location. The replacement connector must have the orange seal installed.**
16. Slide the new connector contact secondary lock (ICA011057) onto the wires.
17. Insert the contacts into a new connector (ICA011058) with the same location and orientation that the wires were in when removed from the old connector. The contact on the black wire inserts into the “B” side of the connector and the contact on the red wire inserts into the “A” side. See **Figure 2**. Ensure that the contacts positively seat into the connector body. A “click” is heard when the contact seats and a gentle tug on the wire confirms.
18. Seat the secondary lock onto the back of the connector to ensure contact retention.
19. Inspect the pin terminals inside both fuel pump connectors. Gently align if necessary. See **Figure 4**.
20. Install new 21.XXXX serial number fuel pump onto baggage floor support bracket using hardware supplied with fuel pump as shown in **Figure 5**.

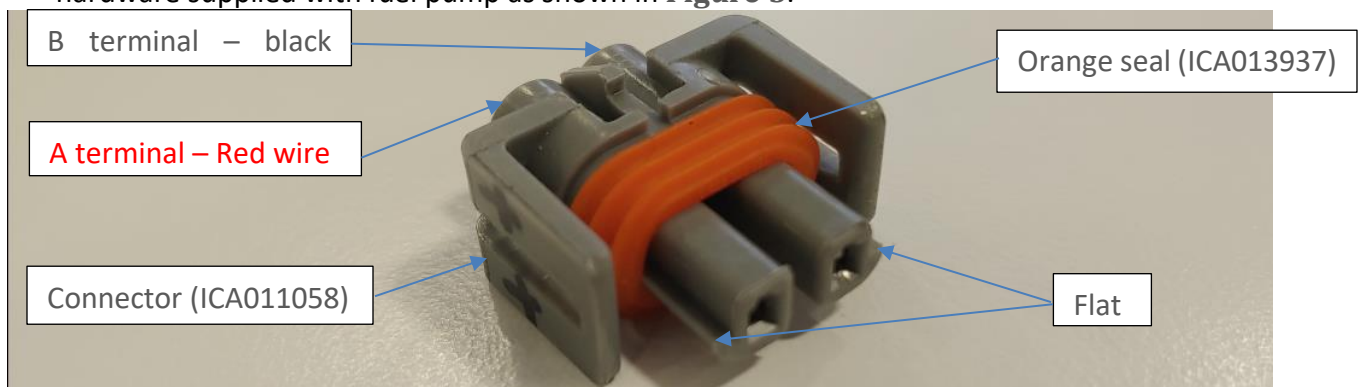

Figure 2: Connector wire locations

SERVICE BULLETIN

SB-112221 REV A

TERMINAL REPLACEMENT SEALED WEATHER PACK AND METRI-PACK

1

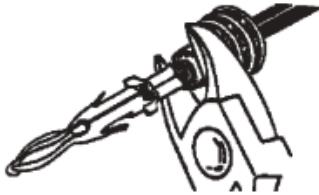

CUT OFF TERMINAL BETWEEN CORE AND INSULATION CRIMP.

(MINIMIZE WIRE LENGTH LOSS)

REMOVE SEAL

2



APPLY CORRECT SEAL PER GAUGE SIZE OF WIRE. SLIDE BACK TO ENABLE REMOVAL OF INSULATION. STRIP 1/4" OF INSULATION.

CAUTION MUST BE USED NOT TO CUT STRANDS

3



ALIGN SEAL WITH CABLE INSULATION

4

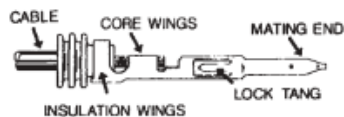

POSITION STRIP AND SEAL IN TERMINAL AS SHOWN. CAUTION MUST BE USED NOT TO POSITION STRIP TOO FAR FORWARD. IT MAY INTERFERE WITH MATING PORTION OF TERMINAL.

Figure 3: Contact preparation

SERVICE BULLETIN

SB-112221 REV A



Figure 4: Fuel Pump pins must be straight

SERVICE BULLETIN

SB-112221 REV A

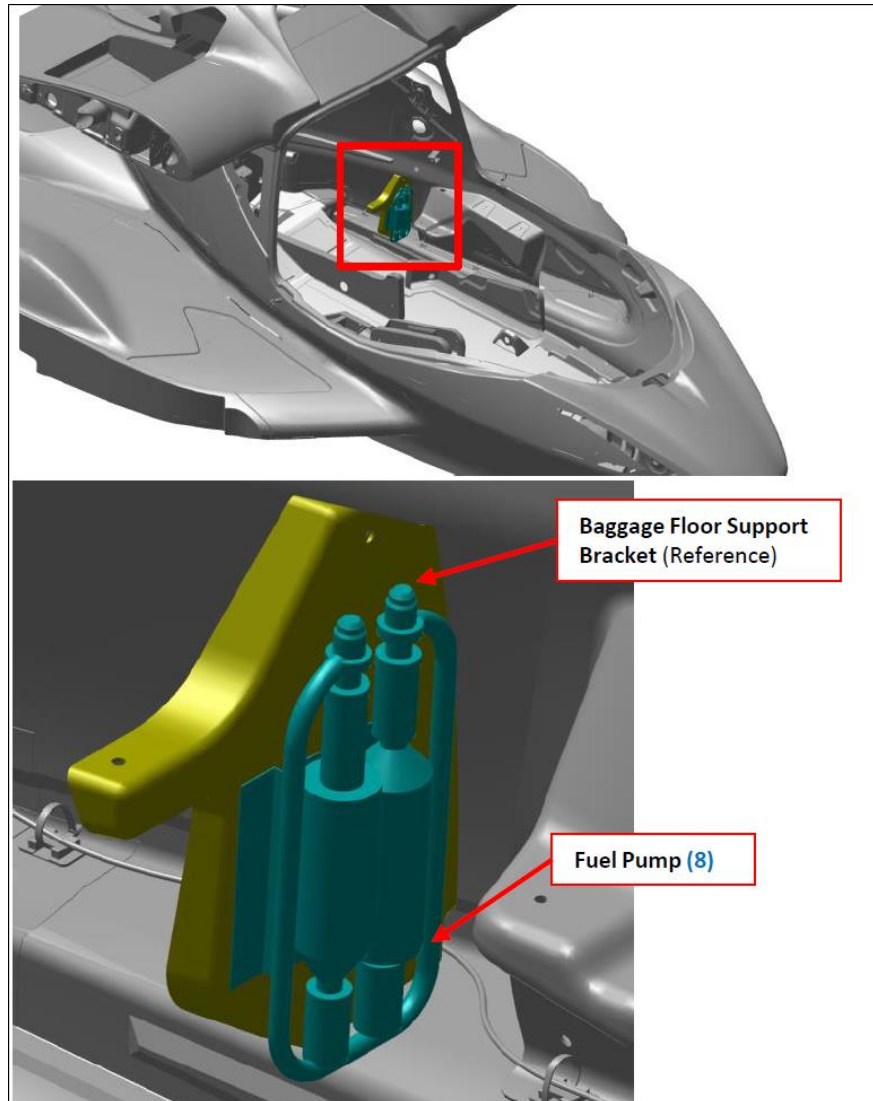
*Figure 5: Fuel Pump Install*

21. Apply Loctite 243 to studs and torque 4x nuts and 4x washers to 30-35 inch-lbs as shown in **Figure 6**. Apply torque stripe to fasteners.

SERVICE BULLETIN

SB-112221 REV A

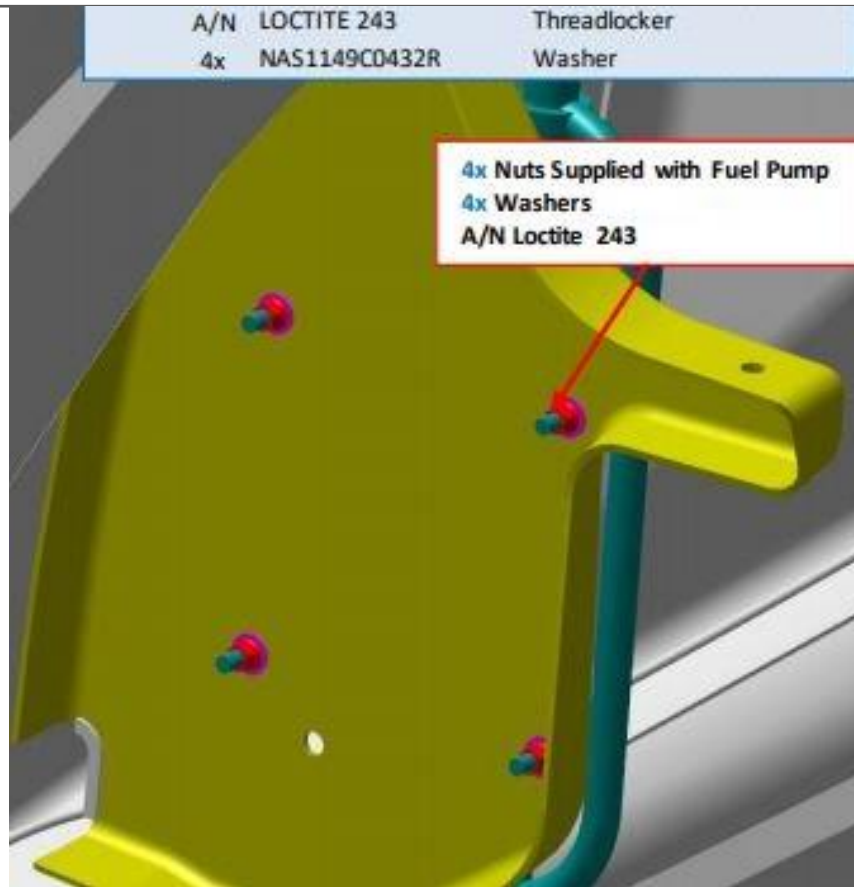

Figure 6: Install washers, nuts, and Loctite 243 on to the mount studs

22. Connect fuel lines to the fuel pump. Torque B-nuts to 110-130 in lbs.
23. Reconnect the D9087P connector onto the bottom connector of the fuel pump.
24. Reconnect the D9100P connector onto the top connector of the fuel pump.
25. Verify locking features of both connectors are engaged.

CORRECTIVE ACTION: FUEL PUMP EXTENSION CONNECTOR INSPECTION

26. It is permissible to disassemble the aircraft as required to permit accessibility, inspection, adjustment, maintenance, and repair in accordance with the latest release of the Aircraft Maintenance Manual.
27. Locate fuel pump extension connectors below aft bulkhead cut-out. See **Figure 7 & 8**.
28. Remove tie wraps and F4 tape, as necessary, to facilitate inspection of the connectors.

SERVICE BULLETIN**SB-112221 REV A**

Figure 7: Fuel Pump Extension Connectors View

SERVICE BULLETIN

SB-112221 REV A

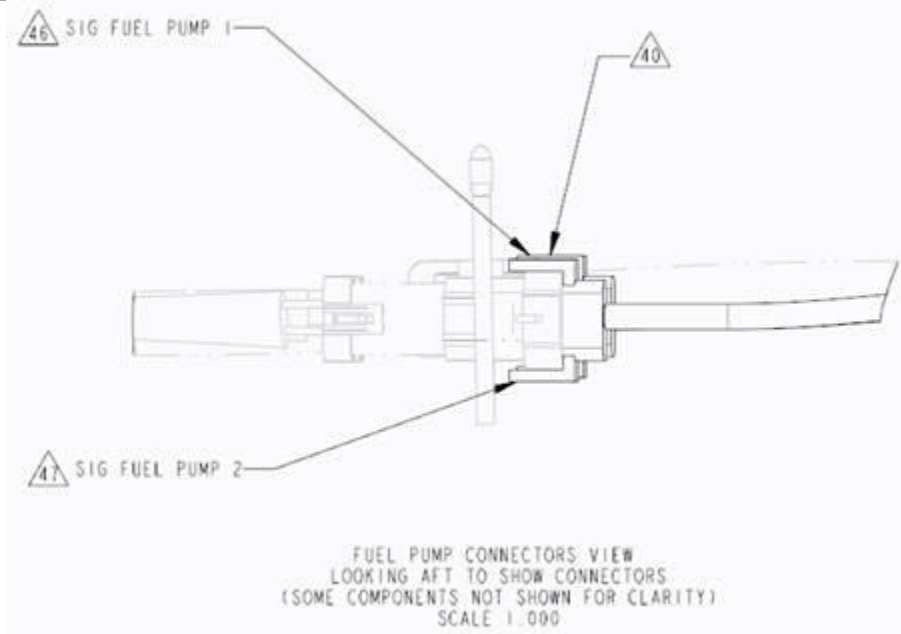

Figure 8: Fuel Pump Extension Connectors Location

29. Disconnect Sig Fuel Pump 1 connector from fuselage wire harness connector D9086J. If necessary, remove zip tie holding connectors to fuselage wire harness.
30. Visually inspect both connectors and ensure that contacts are fully inserted in each connector. Gently slide each wire back and forth to ensure that the contact is locked in position.
31. Reconnect Sig Fuel Pump 1 and D9086J connectors. Ensure secondary locking mechanism is fully engaged in each connector.
32. Disconnect Sig Fuel Pump 2 connector from fuselage wire harness connector D9099J.
33. Visually inspect both connectors and ensure that contacts are fully inserted in each connector. Gently slide each wire back and forth to ensure that the contact is locked in position.



2141 ICON Way, Vacaville, CA 95688 - Tel: 707.564.4000 – www.iconaircraft.com

SERVICE BULLETIN

SB-112221 REV A

34. Reconnect Sig Fuel Pump 2 and D9099J connectors. Ensure secondary locking mechanism is fully engaged in each connector.
35. Install new F4 tape (F4TAPEBLACK) and tie wraps (TY24MX) to secure connectors in place.
36. Reassemble, as required, in accordance with the aircraft maintenance manual.
37. Switch the Master Switch to ON.
38. Rotate Ignition Switch to lane A. Verify fuel pump comes on and primes. Confirm FUEL PRESS light out.
39. Rotate Ignition Switch to lane B. Verify fuel pump comes on and primes. Confirm FUEL PRESS light out.
40. Rotate Ignition Switch to BOTH. Confirm ENGINE and LAND AIRCRAFT lights out.
41. Install the Seat Backs (See "Install Seat Back" on page 3-58 of Maintenance Manual).
42. Install the Seatback Closeout.
43. Install the Baggage Sidewall Panels (See "Baggage Sidewall Panel Installation" on page 3-51 of Maintenance Manual).
44. Install the Baggage Floor (See "Baggage Floor Installation" on page 3-45).
45. Return the affected fuel pump to ICON Aircraft Service at the address below. Prior to sending, contact ICON Service to receive an RMA number. Discard the connectors and contacts removed from the aircraft.

Make the following logbook entry:

"The corrective action of Safety Bulletin SB-112221-A has been complied with and reported to ICON Aircraft Service. Main and Auxiliary fuel pumps serial number _____ and _____ were replaced with Main and Auxiliary fuel pumps serial number _____ and _____."

Warranty Information:

- 1) 3.0 hours for fuel pump assembly inspection, replacement and connector/contact replacement.

If you have questions, comments, or concerns about this Safety Directive/Alert and/or if you are no longer owner/operator of this aircraft, please forward this information to the present owner/operator and notify ICON Aircraft at:

ICON Aircraft
2141 ICON Way
Vacaville, CA 95688
(855) FLY-ICON or (707) 564-4000
support@iconaircraft.com

Please include the aircraft registration number, serial number, your name, and if known the contact information of the new owner/operator.